

QUEEN'S COLLEGE
 Half-yearly Examination, 2009-2010

MATHEMATICS PAPER 1
Question-Answer Book

Secondary 1

Date: 8 – 1 – 2010
 Time: 8:30 am – 9:45 am



1. Write your class, class number in the spaces provided on this cover.
2. This paper consists of TWO sections, A and B. Section A carries 80 marks and Section B carries 40 marks.
3. Attempt ALL questions in this paper. Write your answers in the spaces provided in this Question-Answer Book.
4. Unless otherwise specified, all working must be clearly shown.
5. The diagrams in this paper are not necessarily drawn to scale.
6. Use of calculator is not allowed for this paper.

Class		
Class Number		

Question No.	Max. marks	Teacher's Use Only
1.	5	
2.	5	
3.	6	
4.	7	
5.	8	
6.	8	
7.	9	
8.	10	
9.	11	
10.	11	
11.	20	
12.	20	
Total		

SECTION A Short questions. (80 marks)

Answer ALL questions in this section and write your answers in the spaces provided.

1. (a) Put the correct symbol '<' or '>' between the two given numbers. (Steps are not required for this question.)

(i) $-7\frac{3}{4}$, $-7\frac{7}{12}$ (1 mark)

(ii) $-15\frac{7}{15}$, $-15\frac{9}{17}$ (1 mark)

(iii) -2^3 , -4^2 (1 mark)

(b) Arrange $-7\frac{3}{4}$, $-7\frac{7}{12}$, $-15\frac{7}{15}$, $-15\frac{9}{17}$, -2^3 , -4^2 in ascending order. (2 marks)

(5 marks)

(a) (i)

(ii)

(iii)

(b)

2. It is given that y is a function of x, and $y = x^2(4 + x) - 12$. Find the value of y when $x = -6$.

(5 marks)

3. The length and width of a rectangle are 15 cm and w cm respectively. It is known that the perimeter of the rectangle is not greater than 150 cm.

(a) Formulate an inequality to represent the above situation. (2 marks)

(b) Is it possible that the width of the rectangle is

(i) 65 cm, why? (2 marks)

(ii) 60 cm, why? (2 marks)

(6 marks)

(a)

(b) (i)

(ii)

4. Find the value of P when $\$P$ is deposited in a bank at an interest rate of 12% p.a. for 15 months

(a) if the interest obtained is \$300. (3 marks)

(b) if the amount obtained is \$32 200. (4 marks)

(7 marks)

(a)

(b)

5. The figure shows a glass box with 7 rectangular blocks in it. If the length, width and height of the blocks are 4 cm, 3 cm and 5 cm respectively, estimate

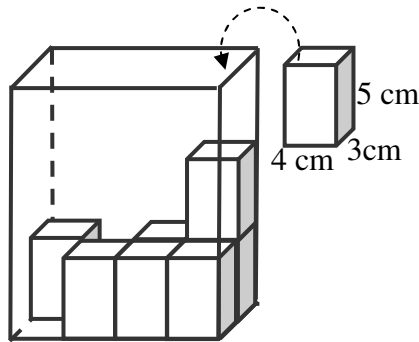

- (a) the smallest possible length of the box. (2 marks)
 - (b) the smallest possible width of the box. (2 marks)
 - (c) the smallest possible height of the box. (2 marks)
 - (d) the smallest possible volume of the box. (2 marks)
- (8 marks)**

(a)

(b)

(c)

(d)

6. (a) Write an algebraic expression for each of the word phrases below:

(i) Subtract b from a .

(2 marks)

(ii) Divide the difference when a is subtracted from b by the sum of a and b .

(b) If $a = -\frac{1}{3}$ and $b = -\frac{1}{5}$, find the value of the phrase (a)(ii).

(6 marks)

(8 marks)

(a) (i)

(ii)

(b)

7. Consider the sequence: $\frac{8}{7}, \frac{9}{14}, \frac{10}{21}, \frac{11}{28}, \dots$

(a) Write down the next 2 terms of the sequence. (2 marks)

(b) (i) Use an algebraic expression to represent the general term a_n of the sequence. (2 marks)

(ii) Use the result of (b)(i) to find the 30th term of the sequence. (2 marks)

(iii) If the m^{th} term of this sequence is $\frac{11}{70}$, find the value of m . (3 marks)

(9 marks)

(a)

(b) (i)

(ii)

(iii)

8. Solve $-\frac{2}{3}(3x + 2) = \frac{x}{2} - \frac{1}{6}(2x - 5)$

(10marks)

9. Refer to the given diagram.

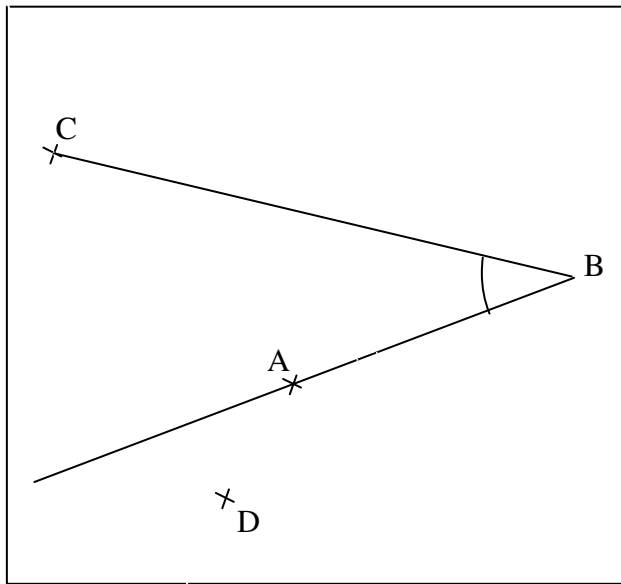

(a) Name the marked angle in the diagram above in 3 different ways. (1 mark)

Answer:

(b) Which type of angle does the marked angle in the diagram belong to? (1 mark)

Answer:

(c) Arrange the following angles in descending order of size:
straight angle, obtuse angle, round angle, right angle, reflex angle, acute angle. (2 marks)

Answer:

(d) In the above diagram,
(i) construct a line passing through D and parallel to AB. (2 marks)
(ii) construct a line passing through C and perpendicular AB. (3 marks)
(iii) mark the intersecting point of 'the lines in (ii)' and 'the line segment AB' as E. (1 mark)

(e) Which 3 points of the above 5 points (A, B, C, D and E) are collinear? (1 mark)

Answer:

(11 marks)

- 10. (a)** Use each of the methods mentioned below to find an estimated value of the expression 225×33 .
- (i)** Round **off** each number in the expression to the nearest ten. (2 marks)
 - (ii)** Round **up** each number in the expression to the nearest ten. (2 marks)
 - (iii)** Round **down** each number in the expression to the nearest ten. (2 marks)
- (b)** In general, which method(s) in **(a)** may give an estimation smaller than the exact value? (1 mark)
- (c)** Judy needs to prepare 33 glasses of wine for a party. Each glass can contain 225 mL. Given that the volume of each bottle of wine is 2 L.
- (i)** Which method in **(a)** should she use to estimate the number of bottles of wine she needs to buy? (1 mark)
 - (ii)** What is the minimum number of bottles of wine she needs to buy? (3 marks)
- (11 marks)**

(a) (i)

(ii)

(iii)

(b)

(c) (i)

(ii)

SECTION B Long Questions. (40 marks)

Answer ALL questions in this section and write your answers in the spaces provided.

Each question carries 20 marks.

11. Tom has a certain number of 50 ¢ ($\$1 = 100 \text{ ¢}$), \$2 and \$5 coins. The number of 50 ¢ coins is three times that of \$2 coins. The number of \$5 coins is 4 more than twice the number of \$2 coins.

(a) If Tom has twenty-two \$2 coins, find

(i) the number of 50 ¢ coins. (2 marks)

(ii) the number of \$5 coins. (2 marks)

(b) If Tom has x \$2 coins, find

(i) the number of 50 ¢ coins in term of x . (1 mark)

(ii) the number of \$5 coins in term of x . (1 mark)

(c) If the total value of the coins is \$263, find the number of each type of coins. (14 marks)

(20 marks)

(a) (i)

(ii)

(b) (i)

(ii)

12. A hawker bought 240 eggs for \$ x . Soon, he found 24 of them are rotten. He marked the price of the remaining eggs at \$1.5 each but can only sold half of them in the market. He then sold all the left over eggs out to a shop at 40% discount off the marked price.

- (a) (i)** Find the number of eggs he sold in the market. (3 marks)
 - (ii)** Find the amount he received from the eggs he sold in the market.. (3 marks)
 - (iii)** Find the amount he received from the eggs he sold to the shop. (4 marks)
 - (iv)** Find x if the overall loss per cent of the hawker is 4%. (6 marks)
 - (b)** The shop sold all the eggs bought from the hawker out at \$1.35 each. Find the profit per cent of this shop. (4 marks)
- (20 marks)

(a) (i)

(ii)

(iii)
